

PHOENIX™ P3G6H™ MULTIPOINT GAUGE VALVE

PRECISION 

MULTIPOINT GAUGE VALVE

3/16" Bore Multiport Gauge Valve

The multiport gauge valve is designed to use with pressure gauges, pressure transmitters and pressure switches. It offers flexible mounting for both vertical and horizontal applications. Phoenix manufactures the valve using barstock construction and a robust stem. Bonnets are pinned for security. Phoenix's innovative design ensures a bubble tight seal. The globe pattern provides maximum shut off utilizing a variety of stem tips, materials and configurations to meet specific applications. All Phoenix valves are built and tested in accordance with MSS-SP105.

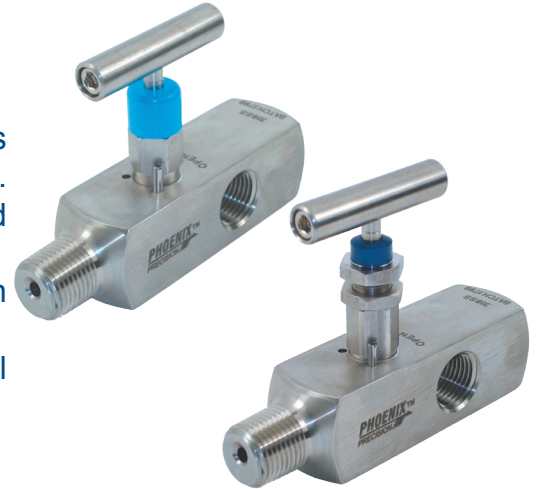

Standard Features

Hydrotested at 150% of rated pressure (shell test). Nitrogen gas tested to 2000 psi.



Seat tightness (zero leakage) verified to 110% of rated pressure. Nitrogen gas tested to 2000 psi.

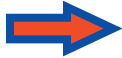

Packing below stem threads



Metal body-to-bonnet seals are in compression, not tension

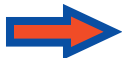

Stem threads are rolled, not cut



8 RMS stem finish



V-Style Teflon™ packing



Pressure component materials sourced from the US, Canada or Europe



Benefits

Complies with ASME B31.1 & B31.3 shell testing procedures as standard. Ensures structural integrity of valve.

Complies with ASME B31.1 & B31.3 seat testing procedures as standard. Ensures zero leakage at seats for proper calibration.

Prevents corrosion of critical stem threads

Mitigates risk of stress cracking

Higher quality stem for longer service life

Extended packing life

30-40% less operational torque and less frequent packing adjustments than traditional Teflon™ packed valves

Reliable material traceability. MTR's provided with every order for pressure containing components.

Solutions for Oil & Gas and Petrochemical Processing
www.phoenixprecisionvalves.com



O-ring Bonnet Gauge Valve

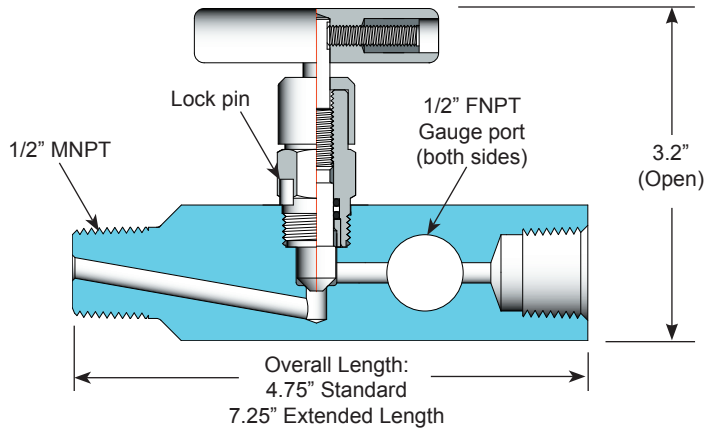

Specifications:

Type: **P3G6H** valve, Globe Pattern
 Rating: Up to 6000 psi @ 100°F
 (41370 kPa @ 38°C)
 Stem: Needle tip or Ball tip
 Packing: Viton™ or Afilas™ O-ring
 Seat: Integral
 Handle: Removable
 Bore Size: 3/16"
 Inlet Connections: 3/8" to 3/4" NPT, SW or FT
 Outlet Connections: 1/2" NPT, SW or FT
 Gauge Ports: 1/2" FNPT
 Bonnet Lock: Pin or Plate
 Body Stock: 1.25" sq
 Weight: 1.5-1.7 lbs (Stand.) 2.4-2.6 lbs (Ext.)
 Special Service: O₂ or CL cleaning available*

*Other specifications or services may be available.

Packed Bonnet Gauge Valve

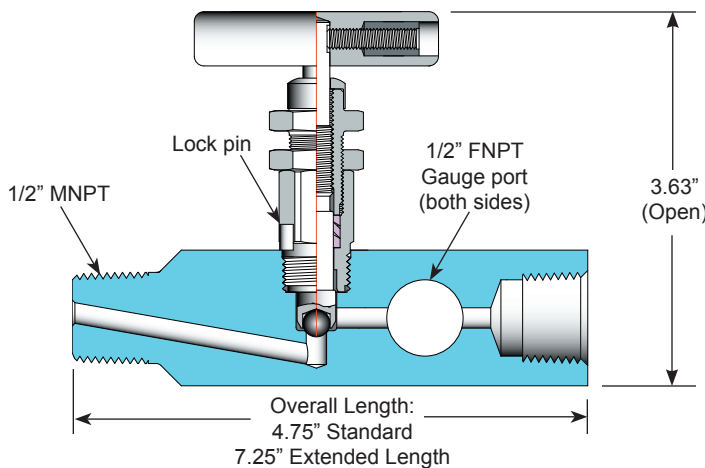

Specifications:

Type: **P3G6H** Valve, Globe Pattern
 Rating: Up to 6000 psi @ 100°F
 (41370 kPa @ 38°C)
 Stem: Needle tip or Ball tip
 Packing: Teflon™ or Grafoil™
 Seat: Integral
 Handle: Removable
 Bore Size: 3/16"
 Inlet Connections: 3/8" to 3/4" NPT, SW or FT
 Outlet Connections: 1/2" NPT, SW or FT
 Gauge Ports: 1/2" FNPT
 Bonnet Lock: Pin or Plate
 Body Stock: 1.25" sq
 Weight: 1.7-1.9 lbs (Stand.) 2.6-2.8 lbs (Ext.)
 Special Service: O₂ or CL cleaning available*

*Other specifications or services may be available.

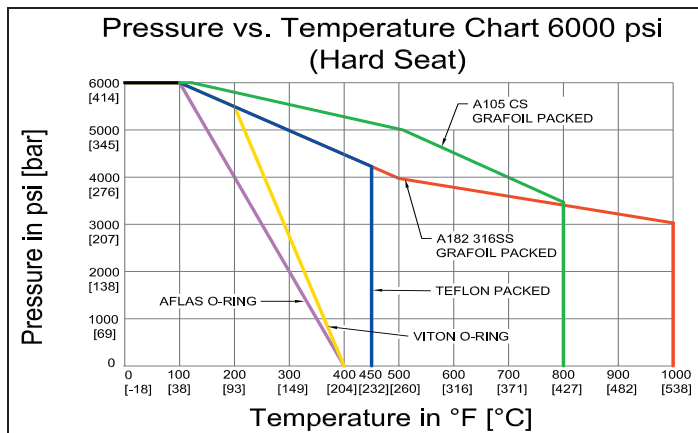

Note: Body material specifications based on ASME B16.34 - 2009. Packing material ratings based on manufacturer's specifications. Approximations only. Phoenix does not represent these values as finite. They are provided only as representative values.

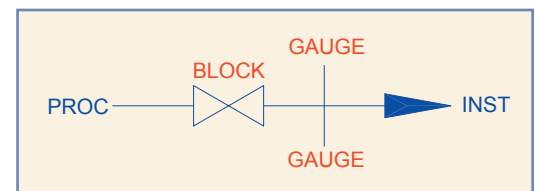

O-Ring Bonnet Assembly

Standard Materials					
Valve	Body	Bonnet	Stem	Ball	Packing
CS	ASTM A108CS	ASTM A108CS	ASTM A582 303SS	SEE OPTION CODES ON PAGE 4	Dual Viton™ O-ring with Teflon™ backup ring
SC	ASTM A105CS	ASTM A182 316SS	ASTM A182 316SS		
316SS	ASTM A182 316SS	ASTM A182 316SS	ASTM A182 316SS		

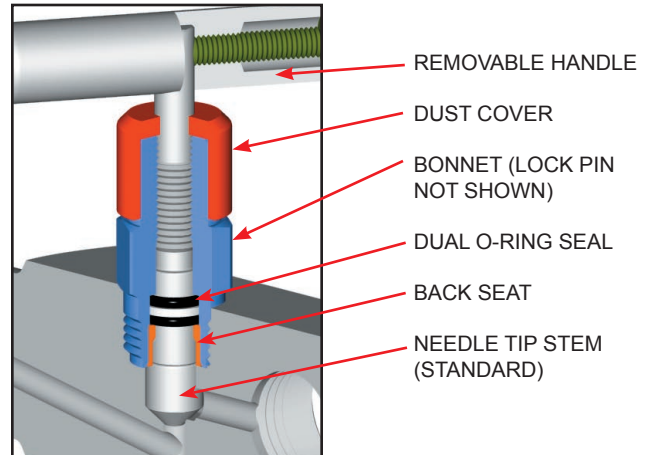

Packed Bonnet Assembly

Standard Materials					
Valve	Body	Bonnet	Stem	Ball	Packing
CS	ASTM A108CS	ASTM A108CS	ASTM A582 303SS	SEE OPTION CODES ON PAGE 4	Teflon™ and Grafoil™
SC	ASTM A105CS	ASTM A182 316SS	ASTM A182 316SS		
316SS	ASTM A182 316SS	ASTM A182 316SS	ASTM A182 316SS		

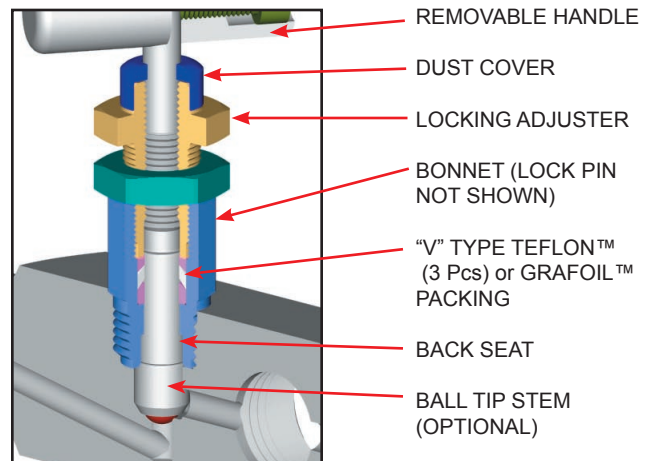

NOTE: Optional low torque Grafoil™ available (G4 Packing Code)

Gauge Valve Accessories	
	<p>Bleed Valve: P2BV6M8M (6M Bonnet) Specifications: Rating: 6000 psi @ 100°F (41370 kpa @ 38°C) Stem: Needle Seat: Integral Handle: Removable Connections: 1/2" NPT Hex Size: 7/8" Weight: 0.4 lbs (Length: 3.12" open installed) *Add SS for A182 316SS, CS for A108CS</p>
	<p>Bleed Plug: P2BP8M Specifications: Rating: 6000 psi @ 100°F (41370 kpa @ 38°C) Stem: Needle Seat: Integral Handle: Removable Connections: 1/2" NPT Hex Size: 7/8" Weight: 0.31 lbs (Length: 2" open installed) *Add SS for A182 316SS, CS for A108CS</p>
	<p>Standard 1/2" Plug: PP8M Specifications: Rating: 10000 psi @ 100°F (68950 kpa @ 38°C) Hex Size: 7/8" Weight: 0.15 lbs (Length: 1") *Add SS for A182 316SS, CS for A108CS</p>

Stem and Seat Configurations

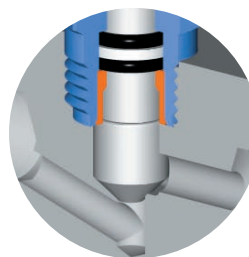

Needle Tip (Standard)

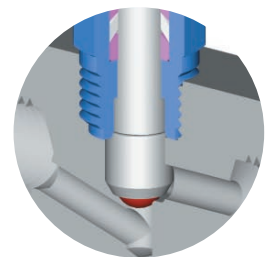

Ball Tip (Optional)

Phoenix	Orifice Size	Type	Inlet Size	Inlet Type	Outlet Size	Outlet Type	Material	Packing	Seat	Stem Tip	Option Codes	Description
P	3=3/16"	G6H (Standard Length, 4.75")	8=1/2"	F=FNPT	8=1/2"	F=FNPT	SS=ASTM A182 316/316L	A=Aflas™	Integral (leave blank)	Needle Tip Standard (leave blank)	BP	Bleed Plug
		GL6H (Extended Length, 7.25")	12=3/4"	M=MNPT		M=MNPT	SC=ASTM A105 CS**	V=Viton™ (FKM)		B=316SS Ball Tip	BV	Bleed Valve
				MS*=Male Socket Weld		MS*=Male Socket Weld	CS=ASTM A108 CS**	T=Teflon™ (PTFE)		BC=Ceramic Ball Tip	PP	Pipe Plug
				FS*=Female Socket Weld		FS*=Female Socket Weld	C5=ASTM A350 LF2	G=Grafoil™		BM=Monel™ Ball Tip	LB	Bonnet Lock
				FT=Female Tube Fitting		FT=Female Tube Fitting	N4=Monel™ 400	G4=Low Torque Grafoil™			CC	Chlorine Clean
							N6=Inconel™ 625				OC	Oxygen Clean
							N8=Inconel™ 825				TG	SS Tag
							N2=Hastelloy™ C276				SGI	Sour Gas ISO NACE Latest Rev.
EXAMPLE: P3G6H8M8FCVSV = 3/16" Orifice, Standard Length, 1/2" MNPT Inlet, 1/2" FNPT Outlet, A108 CS Body, FKM Packing, Integral Seat, Needle Tip Stem												
P	3	G6H	8	M	8	F	CS	V				
*For socket weld (SW) connections, specify MS or FS **For code applications, A108 CS is unacceptable, A105 CS must be selected for CS valves.												

Use with Confidence, Phoenix Precision Products Meet the Following Specifications:

- ✓ ASME B31.1 Power Piping
- ✓ ASME B31.3 Process Piping
- ✓ ASME B16.34 Valves - Flanged, Thread, and Welding End
- ✓ API 598 Valve Inspection and Testing
- ✓ MSS SP-25 Standard Marking Systems for Valves, Fittings and Flange Unions
- ✓ MSS SP-99 Instrument Valves
- ✓ MSS SP-105 Instrument Valves for Code Applications
- ✓ NACE MR0175 for all 316SS valves and A105CS body/316SS bonnet (SC Material Code)

Seal and Seat Material Temperature Rating

Code	Description	MIN. TEMP	MAX. TEMP
A	Aflas™	15°F (-10°C)	400°F (204°C)
V	Viton™	-20°F (-29°C)	400°F (204°C)
T	Teflon™	-65°F (-54°C)	450°F (232°C)
G	Grafoil™ (SS Body)	-70°F (-56°C)	1000°F (537°C)
	Grafoil™ (CS Body)	-70°F (-56°C)	800°F (427°C)

Note: Grafoil™ is suitable for services in excess of 1000°F in a non-oxidizing environment.

For further information please contact:



Phoenix Precision Ltd.
2620 21st Street N.E.
Calgary, Alberta T2E 7L3
Phone:(403) 291-3154
Fax: (403) 291-3292
email: phoenix@phoenixprecision.ca
www.phoenixprecisionvalves.com

Distributor / Representative:

Phoenix Precision Ltd. (PPL) provides the information herein in good faith but makes no representation as to its comprehensiveness or accuracy. The information contained herein is intended only as a guide to PPL products and services. Individuals using information must exercise independent judgment in evaluating product selection and determining product appropriateness for their particular purpose and system requirements. PPL MAKES NO REPRESENTATIONS OR WARRANTIES, EITHER EXPRESS OR IMPLIED, INCLUDING WITHOUT LIMITATION ANY WARRANTIES OF MERCHANTABILITY OR FITNESS FOR A PARTICULAR PURPOSE WITH RESPECT TO THE INFORMATION SET FORTH HEREIN OR THE PRODUCT(S) TO WHICH THE INFORMATION REFERS. ACCORDINGLY, PPL WILL NOT BE RESPONSIBLE FOR DAMAGES (OF ANY KIND OR NATURE, INCLUDING INCIDENTAL, INDIRECT, OR CONSEQUENTIAL DAMAGES) RESULTING FROM THE USE OF OR RELIANCE UPON THIS INFORMATION. Patents and Patents Pending in the U.S. and foreign countries. PPL reserves the right to change product designs and specifications without notice.

DELTRIN, TEFLON, VITON and TEFLOX are registered trademarks (hereinafter referred to as TM) of E.I. Du Pont de Nemours and Company Corporation. PEEK is a registered TM of Whitford Worldwide Company and Whitford B.V. KEL-F is a registered TM of M.W. Kellogg Company. GRAFOIL is a registered TM of High Temperature Materials Inc. and Graftech INC. Corporation. AFLAS is a registered TM of Asahi Glass Co. Ltd. Corporation Japan. MONEL and INCONEL are registered TMs of Huntington Alloys Corporation. HASTELLOY is a registered TM of Haynes International, Inc.

© 2013 by Phoenix Precision Ltd. All rights reserved. Material in this brochure or catalogue may not be reproduced in whole or in part, in any form, without written permission from the publisher.