

**10,000 PSI MULTIPOINT GAUGE VALVE**

**3/16" Bore 10,000 psi Multipoint Gauge Valve**

Phoenix's certified 10,000 psi multipoint gauge valves are proof tested to 20,000 psi and burst tested to 53,000 psi without yield, as per ASME Section VIII, MSS SP-99 and MSS SP-105. These valves feature packing below the threads, back seating capability, blowout proof stem and large 'T' handle for comfort and easy operation.



**Special Features**

Proof tested to 20,000 psi, burst tested to 53,000 psi without yield

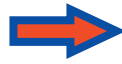

**Benefits**

Certified 10,000 psi valve rating, CRN No. 0C06740.2

**Standard Features**

Hydrotested at 150% of rated pressure (shell test). Nitrogen gas tested to 2000 psi.

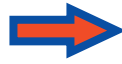

**Benefits**

Complies with ASME B31.1 & B31.3 shell testing procedures as standard. Ensures structural integrity of valve.

Seat tightness (zero leakage) verified to 110% of rated pressure. Nitrogen gas tested to 2000 psi.

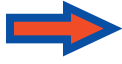

Complies with ASME B31.1 & B31.3 seat testing procedures as standard. Ensures zero leakage at seats for proper calibration.

Packing below stem threads

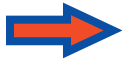

Prevents corrosion of critical stem threads

Metal body-to-bonnet seals are in compression, not tension

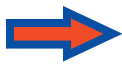

Mitigates risk of stress cracking

Stem threads are rolled, not cut

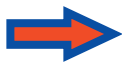

Higher quality stem for longer service life

8 RMS stem finish

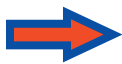

Extended packing life

V-Style Teflon™ packing

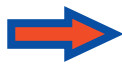

30-40% less operational torque and less frequent packing adjustments than traditional Teflon™ packed valves

Pressure component materials sourced from the US, Canada or Europe



Reliable material traceability. MTR's provided with every order for pressure containing components.

O-ring Bonnet Gauge Valve

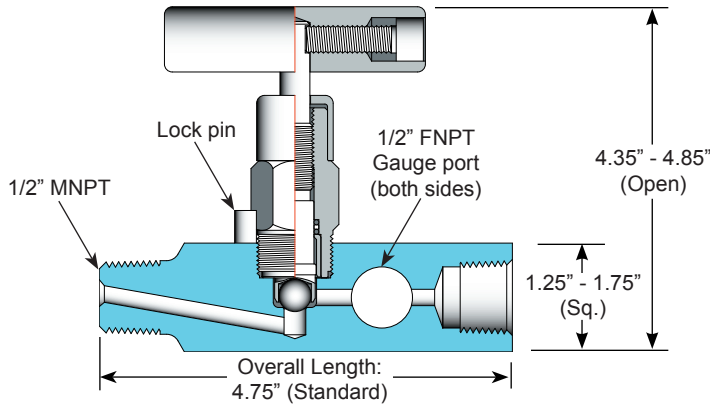

**Specifications:**  
 Type: **P3G10H** valve, Globe Pattern  
 Rating: Up to 10,000 psi @ 100°F  
 (68950 kPa @ 38°C)  
 Stem: Needle tip or Ball tip  
 Packing: Viton™, Aflas™ O-ring or Teflon™  
 Seat: Integral  
 Handle: Removable  
 Bore Size: 3/16"  
 Inlet Connections: 1/4" to 3/4" NPT, 1" for male only  
 Outlet Connections: 1/4" to 3/4" NPT  
 Gauge Ports: 1/2" FNPT (2)  
 Bonnet Lock: Pin or Plate  
 Body Stock: 1.25" - 1.75" sq.  
 Weight: 2.2 - 2.8 lbs  
 Special Service: O<sub>2</sub> or CL cleaning available\*  
 \*Other specifications or services may be available.

O-ring Bonnet Gauge Valve

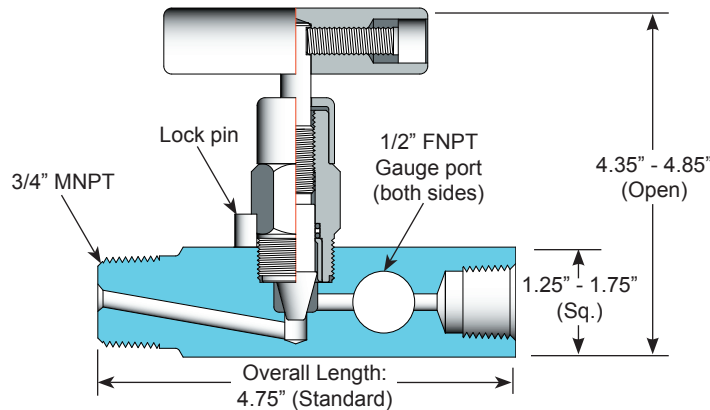

**Specifications:**  
 Type: **P3G10H** Valve, Globe Pattern  
 Rating: Up to 10,000 psi @ 100°F  
 (68950 kPa @ 38°C)  
 Stem: Needle tip or Ball tip  
 Packing: Viton™, Aflas™ O-ring or Teflon™  
 Seat: Integral  
 Handle: Removable  
 Bore Size: 3/16"  
 Inlet Connections: 1/2" to 3/4" NPT, 1" for male only  
 Outlet Connections: 1/2" to 3/4" NPT  
 Gauge Ports: 1/2" FNPT (2)  
 Bonnet Lock: Pin or Plate  
 Body Stock: 1.25" - 1.75" sq.  
 Weight: 2.2 - 2.8 lbs  
 Special Service: O<sub>2</sub> or CL cleaning available\*  
 \*Other specifications or services may be available.

Packed Bonnet Gauge Valve (Extended)

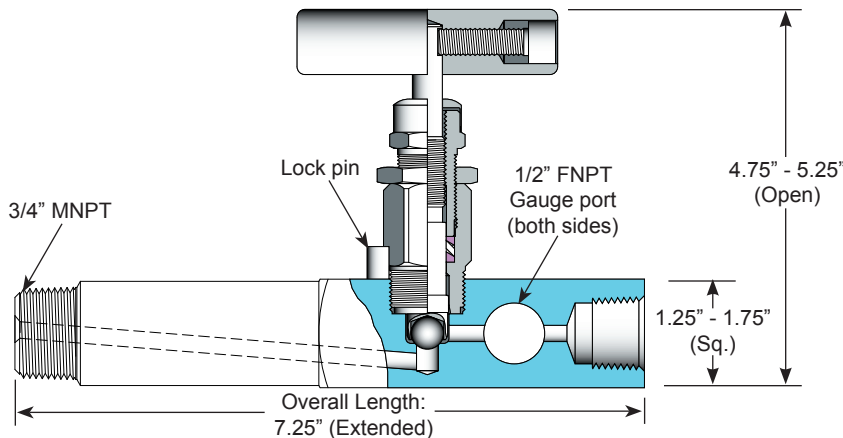

**Specifications:**  
 Type: **P3GL10H** Valve, Globe Pattern  
 Rating: Up to 10,000 psi @ 100°F  
 (68950 kPa @ 38°C)  
 Stem: Needle tip or Ball tip  
 Packing: Viton™, Aflas™ O-ring or Teflon™  
 Seat: Integral  
 Handle: Removable  
 Bore Size: 3/16"  
 Inlet Connections: 1/4" to 3/4" NPT, 1" for male only  
 Outlet Connections: 1/2" to 3/4" NPT  
 Gauge Ports: 1/2" FNPT (2)  
 Bonnet Lock: Pin or Plate  
 Body Stock: 1.25" - 1.75" sq.  
 Weight: 2.9 - 3.5 lbs  
 Special Service: O<sub>2</sub> or CL cleaning available\*  
 \*Other specifications or services may be available.

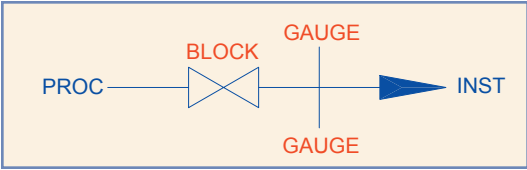

### O-Ring Bonnet Assembly

Standard Materials					
Valve	Body	Bonnet	Stem	Ball	Packing
CS	ASTM A108CS	ASTM A108CS	ASTM A582 303SS	SEE OPTION CODES ON PAGE 4	Dual Viton™ O-ring with Teflon™ backup ring
SC	ASTM A105CS	ASTM A182 316SS	ASTM A182 316SS		
316SS	ASTM A182 316SS	ASTM A182 316SS	ASTM A182 316SS		

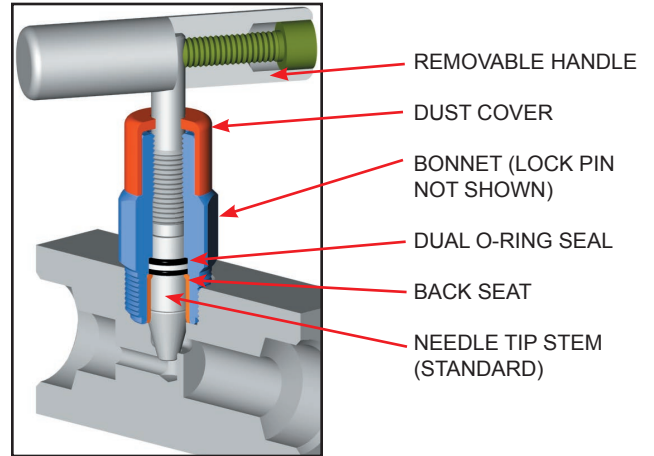

### Packed Bonnet Assembly

Standard Materials					
Valve	Body	Bonnet	Stem	Ball	Packing
CS	ASTM A108CS	ASTM A108CS	ASTM A582 303SS	SEE OPTION CODES ON PAGE 4	Teflon™
SC	ASTM A105CS	ASTM A182 316SS	ASTM A182 316SS		
316SS	ASTM A182 316SS	ASTM A182 316SS	ASTM A182 316SS		

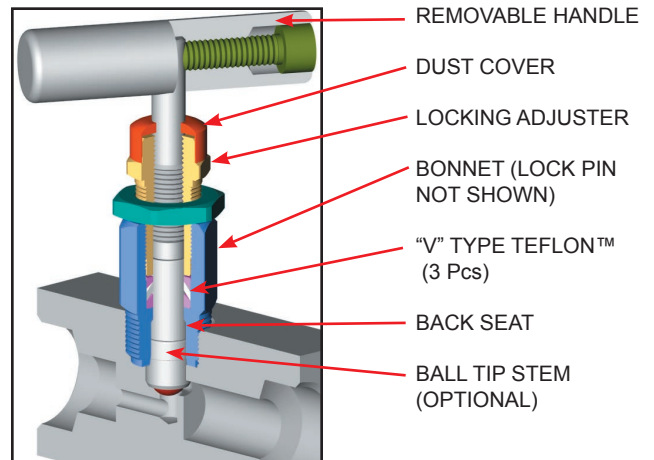

### Stem and Seat Configurations

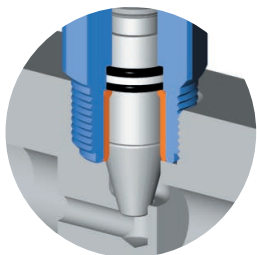

Needle Tip (Standard)

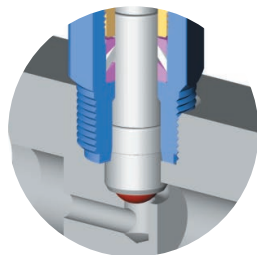

Ball Tip (Optional)

Gauge Valve Accessories	
	<p><b>Standard 1/2" Plug: PP8M</b> Specifications: Rating: 10000 psi @ 100°F (68950 kpa @ 38°C) Hex Size: 7/8" Weight: 0.15 lbs (Length: 1") *Add SS for A182 316SS, CS for A108CS</p>

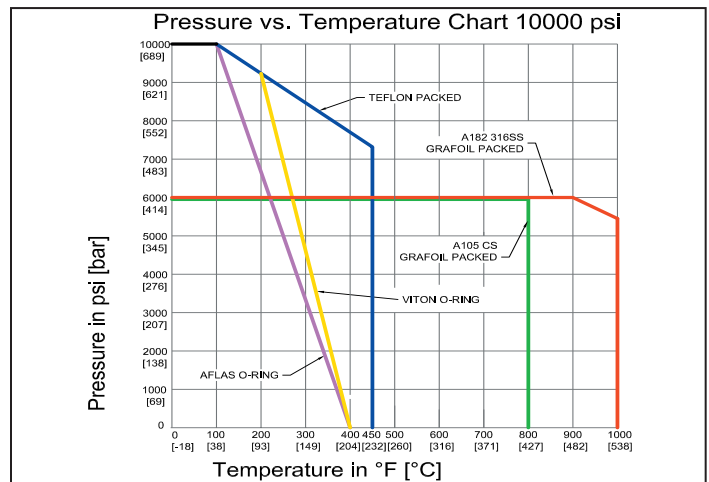

Note: Body material specifications based on ASME B16.34 - 2009. Packing material ratings based on manufacturer's specifications. Approximations only. Phoenix does not represent these values as finite. They are provided only as representative values.

Phoenix	Orifice Size	Type	Inlet Size	Inlet Type	Outlet Size	Outlet Type	Material	Packing	Seat	Stem Tip
P	3=3/16"	G10H	8=1/2"	F=FNPT	8=1/2"	F=FNPT	SS=ASTM A182 316/316L	A=Aflas™	Integral (leave blank)	Needle Tip Standard (leave blank)
		GL10H**	12=3/4"	M=MNPT		M=MNPT	SC=ASTM A105 CS*	V=Viton™ (FKM)		B=316SS Ball Tip
		GXL10H**	16=1" Male only				CS=ASTM A108 CS*	T=Teflon™ (PTFE)		BC=Ceramic Ball Tip
		G10HD=Heavy Duty					C5=ASTM A350 LF2			BM=Monel™ Ball Tip
							N4=Monel™ 400			
							N6=Inconel™ 625			
							N8=Inconel™ 825			
							N2=Hastelloy™ C276			
EXAMPLE: P3G10H8M8FSSVB = Phoenix, 3/16" Orifice, G10H, 1/2" MNPT Inlet, 1/2" FNPT Outlet, 316 SS Body, FKM Packing, Integral Seat, 316 SS Ball Tip Stem										
<b>P</b>	<b>3</b>	<b>G10H</b>	<b>8</b>	<b>M</b>	<b>8</b>	<b>F</b>	<b>SS</b>	<b>V</b>		<b>B</b>
*For code applications, A108 CS is unacceptable, A105 CS must be selected for CS valves. **GL10H for extended length valve body, GXL10H for extra extended length valve body, consult Phoenix Precision for details. <b>Note: This model is available in Grafoil™ packing at a 6000 psi rating.</b>										

Option Codes	Description
LB	Bonnet Lock
PP	Pipe Plug
CC	Chlorine Clean
OC	Oxygen Clean
TG	SS Tag
SGI	Sour Gas ISO NACE Latest Rev.
N4	Monel™ 400 Stem
N5	Monel™ 500 Stem
N6	Inconel™ 625 Stem
N8	Inconel™ 825 Stem
N2	Hastelloy™ C276 Stem

**Use with Confidence, Phoenix Precision Products Meet the Following Specifications:**

- ✓ ASME B31.1 Power Piping
- ✓ ASME B31.3 Process Piping
- ✓ ASME B16.34 Valves - Flanged, Thread, and Welding End
- ✓ API 598 Valve Inspection and Testing
- ✓ MSS SP-25 Standard Marking Systems for Valves, Fittings and Flange Unions
- ✓ MSS SP-99 Instrument Valves
- ✓ MSS SP-105 Instrument Valves for Code Applications
- ✓ NACE MR0175 for all 316SS valves and A105CS body/316SS bonnet (SC Material Code)

**Seal and Seat Material Temperature Rating**

Code	Description	MIN. TEMP	MAX. TEMP
A	Aflas™	15°F (-10°C)	400°F (204°C)
V	Viton™	-20°F (-29°C)	400°F (204°C)
T	Teflon™	-65°F (-54°C)	450°F (232°C)

**For further information please contact:**



Phoenix Precision Ltd.  
2620 21st Street N.E.  
Calgary, Alberta T2E 7L3  
Phone:(403) 291-3154  
Fax: (403) 291-3292  
email: phoenix@phoenixprecision.ca  
www.phoenixprecisionvalves.com

**Distributor / Representative:**

Phoenix Precision Ltd. (PPL) provides the information herein in good faith but makes no representation as to its comprehensiveness or accuracy. The information contained herein is intended only as a guide to PPL products and services. Individuals using information must exercise independent judgment in evaluating product selection and determining product appropriateness for their particular purpose and system requirements. PPL MAKES NO REPRESENTATIONS OR WARRANTIES, EITHER EXPRESS OR IMPLIED, INCLUDING WITHOUT LIMITATION ANY WARRANTIES OF MERCHANTABILITY OR FITNESS FOR A PARTICULAR PURPOSE WITH RESPECT TO THE INFORMATION SET FORTH HEREIN OR THE PRODUCT(S) TO WHICH THE INFORMATION REFERS. ACCORDINGLY, PPL WILL NOT BE RESPONSIBLE FOR DAMAGES (OF ANY KIND OR NATURE, INCLUDING INCIDENTAL, INDIRECT, OR CONSEQUENTIAL DAMAGES) RESULTING FROM THE USE OF OR RELIANCE UPON THIS INFORMATION. Patents and Patents Pending in the U.S. and foreign countries. PPL reserves the right to change product designs and specifications without notice.

DELTRIN, TEFLON and VITON are registered trademarks (hereinafter referred to as TM) of E.I. Du Pont De Nemours and Company Corporation. PEEK is a registered TM of Whitford Worldwide Company and Whitford B.V. KEL-F is a registered TM of M.W. Kellogg Company. GRAFOIL is a registered TM of High Temperature Materials Inc. and Graftech INC. Corporation. AFLAS is a registered TM of Asahi Glass Co. Ltd. Corporation Japan. MONEL and INCONEL are registered TMs of Huntington Alloys Corporation. HASTELLOY is a registered TM of Haynes International, Inc.

© 2013 by Phoenix Precision Ltd. All rights reserved. Material in this brochure or catalogue may not be reproduced in whole or in part, in any form, without written permission from the publisher.