

# PHOENIX™ P3B6H™ INTEGRAL BLEED VALVE

PRECISION 

## INTEGRAL BLEED VALVE

### 3/16" Bore Integral Bleed Valve

The integral bleed valve is designed to use with pressure gauges and pressure switches. The valve is built using bar stock construction, a robust stem, and bonnets pinned for security. The valve's globe pattern provides maximum shut-off. Phoenix offers the valve in a variety of stem tips, materials and configurations that meet most application requirements.

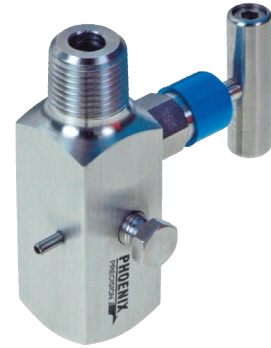

#### Standard Features

#### Benefits

Hydrotested at 150% of rated pressure (shell test). Nitrogen gas tested to 2000 psi.

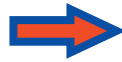

Complies with ASME B31.1 & B31.3 shell testing procedures as standard. Ensures structural integrity of valve.

Seat tightness (zero leakage) verified to 110% of rated pressure. Nitrogen gas tested to 2000 psi.

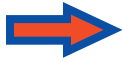

Complies with ASME B31.1 & B31.3 seat testing procedures as standard. Ensures zero leakage at seats for proper calibration.

Packing below stem threads

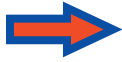

Prevents corrosion of critical stem threads

Metal body-to-bonnet seals are in compression, not tension

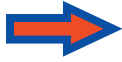

Mitigates risk of stress cracking

Stem threads are rolled, not cut

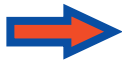

Higher quality stem for longer service life

8 RMS stem finish

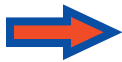

Extended packing life

V-Style Teflon™ packing

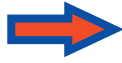

30-40% less operational torque and less frequent packing adjustments than traditional Teflon™ packed valves

Pressure component materials sourced from the US, Canada or Europe

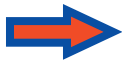

Reliable material traceability. MTR's provided with every order for pressure containing components.

Solutions for Oil & Gas and Petrochemical Processing  
[www.phoenixprecisionvalves.com](http://www.phoenixprecisionvalves.com)



### O-Ring Bonnet Configuration

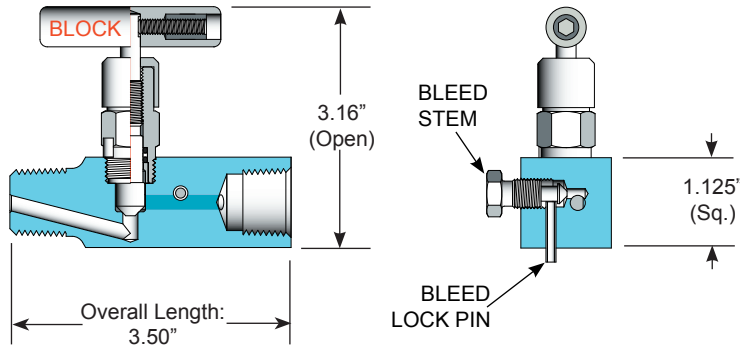

#### Specifications:

Type: **P3B6H** Valve, Globe Pattern  
 Rating: Up to 6000 psi @ 100°F  
 (41370 kPa @ 38°C)  
 Stem: Needle tip or Ball tip  
 Packing: Viton™ O-ring, Teflon™ or Grafoil™  
 Seat: Integral  
 Handle: Removable  
 Bore Size: 3/16", 1/8" for Bleed  
 Inlet Connections: 1/2" NPT, SW or FT, (3/4" for male NPT, SW Only)  
 Outlet Connections: 1/2" NPT, SW or FT  
 Bleed Port: 1/8" Pin  
 Bonnet Lock: Pin or Plate  
 Body Stock: 1.125" sq  
 Weight: 1.13 lbs  
 Special Service: O<sub>2</sub> or CL cleaning available\*

\*Other specifications or services may be available.

### Teflon™ Bonnet Configuration

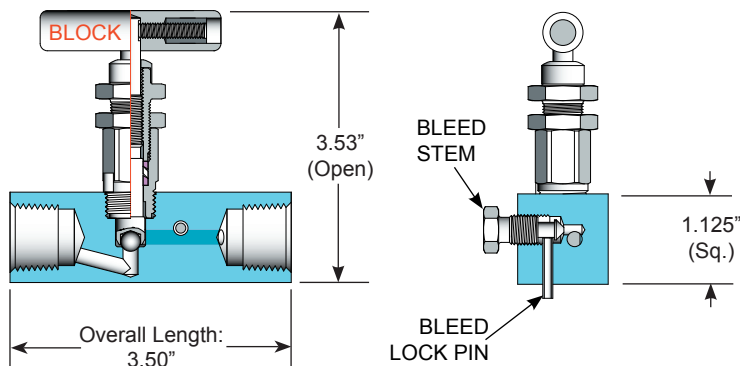

#### Specifications:

Type: **P3B6H** Valve, Globe Pattern  
 Rating: Up to 6000 psi @ 100°F  
 (41370 kPa @ 38°C)  
 Stem: Needle tip or Ball tip  
 Packing: Viton™ O-ring, Teflon™ or Grafoil™  
 Seat: Integral  
 Handle: Removable  
 Bore Size: 3/16", 1/8" for Bleed  
 Inlet Connections: 1/2" NPT, SW or FT, (3/4" for male NPT, SW Only)  
 Outlet Connections: 1/2" NPT, SW or FT  
 Bleed Port: 1/8" Pin  
 Bonnet Lock: Pin or Plate  
 Body Stock: 1.125" sq  
 Weight: 1.19 lbs  
 Special Service: O<sub>2</sub> or CL cleaning available\*

\*Other specifications or services may be available.

### Grafoil™ Bonnet Configuration

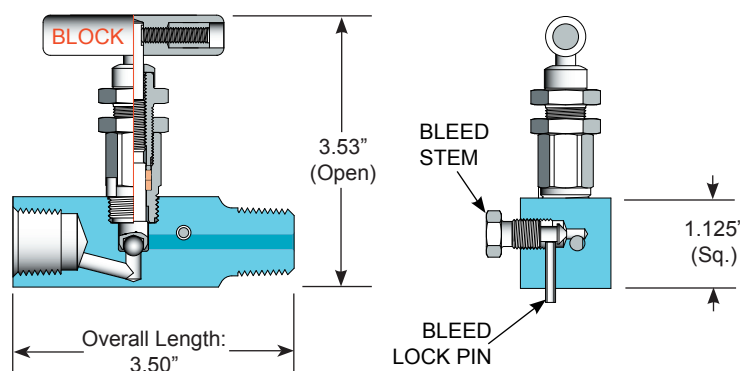

#### Specifications:

Type: **P3B6H** Valve, Globe Pattern  
 Rating: Up to 6000 psi @ 100°F  
 (41370 kPa @ 38°C)  
 Stem: Needle tip or Ball tip  
 Packing: Viton™ O-ring, Teflon™ or Grafoil™  
 Seat: Integral  
 Handle: Removable  
 Bore Size: 3/16", 1/8" for Bleed  
 Inlet Connections: 1/2" NPT, SW or FT, (3/4" for male NPT, SW Only)  
 Outlet Connections: 1/2" NPT, SW or FT  
 Bleed Port: 1/8" Pin  
 Bonnet Lock: Pin or Plate  
 Body Stock: 1.125" sq  
 Weight: 1.19 lbs  
 Special Service: O<sub>2</sub> or CL cleaning available\*

\*Other specifications or services may be available.

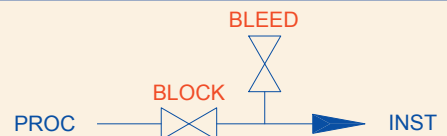

### O-Ring Bonnet Assembly

Standard Materials					
Valve	Body	Bonnet	Stem	Ball	Packing
CS	ASTM A108CS	ASTM A108CS	ASTM A582 303SS	SEE OPTION CODES ON PAGE 4	Dual Viton™ O-ring with Teflon™ backup ring
SC	ASTM A105CS	ASTM A182 316SS	ASTM A182 316SS		
316SS	ASTM A182 316SS	ASTM A182 316SS	ASTM A182 316SS		

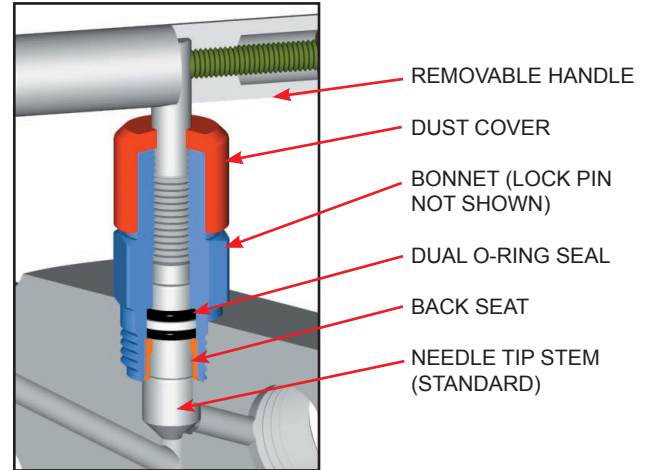

### Teflon™ or Grafoil™ Bonnet Assembly

Standard Materials					
Valve	Body	Bonnet	Stem	Ball	Packing
CS	ASTM A108CS	ASTM A108CS	ASTM A582 303SS	SEE OPTION CODES ON PAGE 4	Teflon™ and Grafoil™
SC	ASTM A105CS	ASTM A182 316SS	ASTM A182 316SS		
316SS	ASTM A182 316SS	ASTM A182 316SS	ASTM A182 316SS		

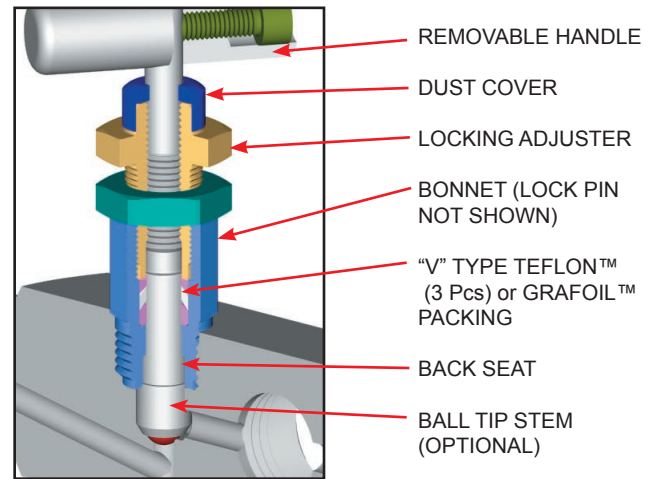

NOTE: Low torque Grafoil™ available (G4 Packing Code)

### Stem and Seat Configurations

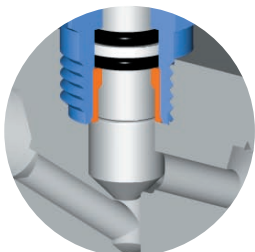

Needle Tip (Standard)

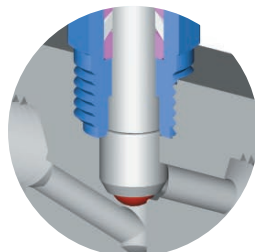

Ball Tip (Optional)

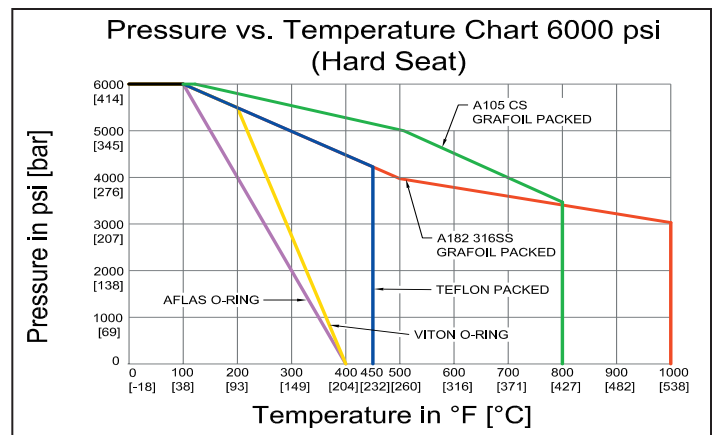

Note: Body material specifications based on ASME B16.34 - 2009. Packing material ratings based on manufacturer's specifications. Approximations only. Phoenix does not represent these values as finite. They are provided only as representative values.

Phoenix	Orifice Size	Type	Inlet Size	Inlet Type	Outlet Size	Outlet Type	Material	Packing	Seat	Stem Tip	Option Codes	Description
P	3=3/16"	B6H	8=1/2"	F=FNPT	8=1/2"	F=FNPT	SS=ASTM A182 316/316L	A=Aflas <sup>TM</sup>	Integral (leave blank)	Needle Tip Standard (leave blank)	LB	Bonnet Lock
			12=3/4" (Male only)	M=MNPT	12=3/4" (Male only)	M=MNPT	SC=ASTM A105 CS**	V=Viton <sup>TM</sup> (FKM)		B=316SS Ball Tip	CC	Chlorine Clean
				MS*=Male Socket weld		MS*=Male Socket weld	CS=ASTM A108 CS**	T=Teflon <sup>TM</sup> (PTFE)		BC=Ceramic Ball Tip	OC	Oxygen Clean
				FS*=Female Socket weld		FS*=Female Socket weld	C5=ASTM A350 LF2	G=Grafoil <sup>TM</sup>		BM=Monel <sup>TM</sup> Ball Tip	TG	SS Tag
				FT=Female Tube Fitting		FT=Female Tube Fitting	N4=Monel <sup>TM</sup> 400	G4=Low Torque Grafoil <sup>TM</sup>			SGI	Sour Gas ISO NACE Latest Rev.
							N6=Inconel <sup>TM</sup> 625				RA (R)(B)	Round Handle Aluminum (Red)(Blue)
							N8=Inconel <sup>TM</sup> 825				RC	Round Handle CS
							N2=Hastelloy <sup>TM</sup> C276				RS	Round Handle SS
EXAMPLE: P3B6H8M8FSSV = Phoenix, 3/16" Orifice, Integral Bleed Valve, 1/2" MNPT Inlet, 1/2" FNPT Outlet, 316 SS Body, Viton <sup>TM</sup> O-ring Packing, Needle Tip Stem												
<b>P</b>	<b>3</b>	<b>B6H</b>	<b>8</b>	<b>M</b>	<b>8</b>	<b>F</b>	<b>SS</b>	<b>V</b>			N4	Monel <sup>TM</sup> 400 Stem
											N5	Monel <sup>TM</sup> 500 Stem
											N6	Inconel <sup>TM</sup> 625 Stem
											N8	Inconel <sup>TM</sup> 825 Stem
											N2	Hastelloy <sup>TM</sup> C276 Stem

\*For socket weld (SW) connections, specify MS or FS.

\*\*For code applications, A108 CS is unacceptable, A105 CS must be selected for CS valves.

### Use with Confidence, Phoenix Precision Products Meet the Following Specifications:

- ✓ ASME B31.1 Power Piping
- ✓ ASME B31.3 Process Piping
- ✓ ASME B16.34 Valves - Flanged, Thread, and Welding End
- ✓ API 598 Valve Inspection and Testing
- ✓ MSS SP-25 Standard Marking Systems for Valves, Fittings and Flange Unions
- ✓ MSS SP-99 Instrument Valves
- ✓ MSS SP-105 Instrument Valves for Code Applications
- ✓ NACE MR0175 for all 316SS valves and A105CS body/316SS bonnet (SC Material Code)

### Seal and Seat Material Temperature Rating

Code	Description	MIN. TEMP	MAX. TEMP
A	Aflas <sup>TM</sup>	15°F (-10°C)	400°F (204°C)
V	Viton <sup>TM</sup>	-20°F (-29°C)	400°F (204°C)
T	Teflon <sup>TM</sup>	-65°F (-54°C)	450°F (232°C)
G	Grafoil <sup>TM</sup> (SS Body)	-70°F (-56°C)	1000°F (537°C)
	(CS Body)	-70°F (-56°C)	800°F (427°C)

Note: Grafoil<sup>TM</sup> is suitable for services in excess of 1000°F in a non-oxidizing environment.

### For further information please contact:



SAI GLOBAL  
ISO 9001  
Quality

Phoenix Precision Ltd.  
2620 21st Street N.E.  
Calgary, Alberta T2E 7L3  
Phone:(403) 291-3154  
Fax: (403) 291-3292  
email: phoenix@phoenixprecision.ca  
www.phoenixprecisionvalves.com

### Distributor / Representative:

Phoenix Precision Ltd. (PPL) provides the information herein in good faith but makes no representation as to its comprehensiveness or accuracy. The information contained herein is intended only as a guide to PPL products and services. Individuals using information must exercise independent judgment in evaluating product selection and determining product appropriateness for their particular purpose and system requirements. PPL MAKES NO REPRESENTATIONS OR WARRANTIES, EITHER EXPRESS OR IMPLIED, INCLUDING WITHOUT LIMITATION ANY WARRANTIES OF MERCHANTABILITY OR FITNESS FOR A PARTICULAR PURPOSE WITH RESPECT TO THE INFORMATION SET FORTH HEREIN OR THE PRODUCT(S) TO WHICH THE INFORMATION REFERS. ACCORDINGLY, PPL WILL NOT BE RESPONSIBLE FOR DAMAGES (OF ANY KIND OR NATURE, INCLUDING INCIDENTAL, INDIRECT, OR CONSEQUENTIAL DAMAGES) RESULTING FROM THE USE OF OR RELIANCE UPON THIS INFORMATION. Patents and Patents Pending in the U.S. and foreign countries. PPL reserves the right to change product designs and specifications without notice.

DELFIN, TEFLON and VITON are registered trademarks (hereinafter referred to as TM) of E.I. Du Pont de Nemours and Company Corporation. PEEK is a registered TM of Whitford Worldwide Company and Whitford B.V. KEL-F is a registered TM of M.W. Kellogg Company. GRAFOIL is a registered TM of High Temperature Materials Inc. and Graftech INC. Corporation. AFLAS is a registered TM of Asahi Glass Co. Ltd. Corporation Japan. MONEL and INCONEL are registered TMs of Huntington Alloys Corporation. HASTELLOY is a registered TM of Haynes International, Inc.

© 2013 by Phoenix Precision Ltd. All rights reserved. Material in this brochure or catalogue may not be reproduced in whole or in part, in any form, without written permission from the publisher.